

PICTURE LIGHTS

PictureLights

Slim unobtrusive designs • Two body styles • Fluorescent or Xenon lamp options • UV filters for fine art applications • Electronic control gear

PL T2 and PL X are designed to light paintings and artwork effectively; which means with adequate light and good colour rendering. Depending on the finishes specified, they will suit projects with either period or contemporary furnishings and décor.

For specific projects custom designs may be available dependent on quantities and lead times. Contact Technical Dept. for advice.



PICTURE LIGHTS

PL T2 Picture Light

PL T2 is a slim, high output, low energy picture light. It has an egg shaped profile to house the lamp and reflector, which means the viewed profile is a slim 27mm Ø tube. Made of aluminium extrusions and die-castings, these units are very light and can be supplied in a variety of finishes.

T2 triphosphor lamps have an excellent colour rendering ideal for paintings and photographs with a UV filter available for use with sensitive materials and valuable artwork. The lamps and reflector system also produce even illumination with soft cut-off lines, so a wide painting can easily be lit with 2 or more fittings.

The high frequency control gear is housed in the slim integral wall-mounted housing, hard wired from behind.

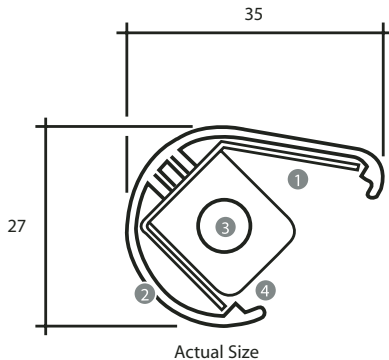

∇F $t_a 40^\circ C$

- 1 Aluminium Reflector
- 2 Body section
- 3 T2 Fluorescent Lamp
- 4 T2 Lampholder

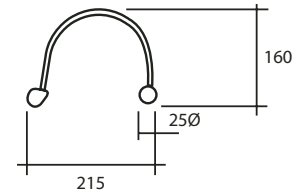
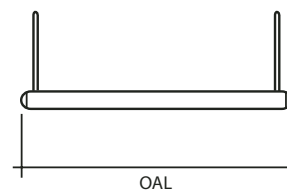

PICTURE LIGHTS

Mounting

The control gear housing can be mounted above the picture frame when the frame is fixed flush to the wall, or alternatively, concealed behind the top rail of the frame when the picture is suspended by hook and wire.

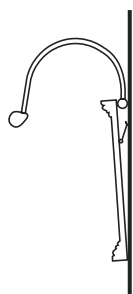

Hook and wire mounted

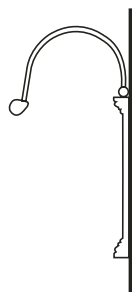

Flush mounted

Control Gear

Control gear is High Frequency electronic, providing flicker free lamp strike, short and open circuit protection with thermal overload and end of life protection.

Lamps

T2 lamps, only 7mm in diameter, are krypton filled triphosphor fluorescent lamps with an excellent colour rendering of 85/1B. They are available in three colour temperatures: 3000, 4000, 6000K and in outputs: 8, 11 and 13W.

Finish Options for PL T2

Powder coated white / black
Satin Brass finish
Polished Chrome

Lamps - Colour Temperatures and Filter code

Colour Temp.	Description	Suffix
3000K	Warm White	
4000K	White	
6000K	Daylight (Colour Matching)	
Filter	UV absorption filter	/UVF

Order codes for PL T2

Product Code	Lamp	Initial Lumens	OAL (mm)
PL T2 08	8W	540	415
PL T2 11	11W	750	515
PL T2 13	13W	930	615

PICTURE LIGHTS

PL X Picture Light

PL X has brass components in similar style to PL T2, but a slightly larger profile to accommodate our XenLight system with 20,000 hour loop ended Xenon lamps, which do not emit UV. This provides a fully dimmable fitting with a warm colour temperature light source (2400K) which is ideal for leisure projects such as restaurants, clubs and hotel reception areas. Being brass means that when a traditional style is required the antique finish is much more effective.

Supplied as standard with 5W lamps at 55mm centres, alternate lamps can be removed to reduce the luminance by 50% and if a softer lighting effect is required the lamps can be specified frosted. Three standard sizes are available, but for small production runs we can manufacture other lengths.

PL X picture lights require a remote 24V transformer.

Finish Options for PL X

Powder coated white / black
Polished Chrome
Polished Brass, Patinated (antique) Brass

Order codes for PL X standard lengths

Product Code	Lamp Qty	Load	lumens	OAL (mm)
PL X 10/05	10	50W	400 lm	640
PL X 20/05	20	100W	800 lm	1190
PL X 27/05	27	135W	1080 lm	1575

If frosted lamps are required add F to the product code ie. PL X 20/05F

